



CE

# FSG 70

## VHF/AM COM TRANSCEIVER

118.000 ... 136.975 MHz



CE

# FSG 71M

## VHF/AM COM TRANSCEIVER

118.000 ... 136.975 MHz

---

## Installation & Operation Manual

applies for FSG 70, article no. F10002  
applies for FSG 71M, article no. F10003

---

*Before installing and operating the radio,  
read this manual thoroughly, please!*

*Please observe the Safety Information!*

*Keep for further use!*

Document No.

027.HB.00E

Revision No.

(Reprint) 1

Date/Issue

July 1998



Walter **DITTEL** GmbH  
Luftfahrtgerätebau

### Avionics Division

Erpfinger Strasse 36 ★ D-86899 Landsberg ★ Germany  
Telephone +49 8191/3351-0 ★ Fax +49 8191/3351-49  
e-mail: firma@dittel.com ★ Internet: <http://www.dittel.com>

## Warranty - Copyright - Service

### Warranty

The details and data in this operator's manual correspond to the respective state of technology on the day of printing. We reserve our right to change without prior notice due to new technological design or corresponding new production technology.

WALTER DITTEL GmbH takes no guarantee for these documents with respect to application and interpretation.

WALTER DITTEL GmbH ("Warrantor") warrants to the purchaser of new radio equipment of the warrantor's manufacture that such equipment shall be free from defects in material and workmanship for a period of 24 month from the date of delivery. Equipment and accessory items not manufactured by the Warrantor carry the standard warranty (12 month) of the manufacturer thereof.

**This warranty does not cover equipment which has been**

- 1. damaged or not maintained as reasonable and necessary,**
- 2. modified in any way,**
- 3. improperly installed,**
- 4. repaired by someone other than the warrantor or an authorized warranty repair station, or**
- 5. used in a manner or purpose for which the equipment was not intended.**

This warranty shall not extend to incidental or consequential damages arising from operation of the equipment or from any claimed breach of this warranty.

### Copyright © 1990 Walter Dittel GmbH, reprint July 1998

All rights reserved. This document contains proprietary information and such information may not be disclosed to others for any purpose nor used for manufacturing purposes without prior written permission of the manufacturer Walter Dittel GmbH, Luftfahrtgeraetebau, D-86899 Landsberg am Lech, Germany.

In this document no mention is made of patents, trademark rights, or other proprietary rights which may attach to certain words or entries. The absence of such mention, however, in no way implies that the words or entries in question are exempt from such rights.

### Service

The information in this Operator's Manual does not profess to include all the details of design, production, or variation of the equipment, or to cover all the possible contingencies which may arise during operation or maintenance.

Should any unusual problem arise or further information be desired, please contact the Walter Dittel GmbH Service Department, Erpftinger Strasse 36, D-86899 Landsberg am Lech, Germany.

Since May 1994 the company  
ANTON LANG FLUGFUNK-SERVICE  
Pappelweg 26  
D-86972 Schwabniederhofen  
Germany

Tel: +49-8861 / 1739

Fax: +49-8861 / 1590

took over all repair work of airband radios of Walter Dittel GmbH, Luftfahrtgeraetebau, Erpftinger Stasse 36, D-86899 Landsberg am Lech, Germany.

The offered services of company LANG include all repairs, overhaul, maintenance and inspection according to the regulations of the German Federal Aviation Authority (Luftfahrtbundesamt, LBA). The company LANG is an authorized repair station, certified by the LBA under registration number II-A272.

**IMPORTANT:** Also all warranty repairs are done solely by company LANG.

Subject to technical changes

Printed in Germany

03.05.01

**SALE OF NEW AND  
SECOND-HAND RADIOS!**

## Table of contents

Paragraph	Page
Warranty - Copyright - Service .....	ii
Table of contents .....	iii
List of illustrations .....	iv
List of valid pages .....	iv
<b>Section I, Safety Information .....</b>	<b>1-1</b>
1.1 Used Symbols .....	1-2
<b>Section II, General Information .....</b>	<b>2-1</b>
2.1 Introduction .....	2-1
2.2 Application .....	2-1
2.3 Brief Description .....	2-2
2.4 FSG 70-System Technical Data .....	2-3
2.4.1 General Data .....	2-3
2.4.2 Receiver Electrical Data .....	2-4
2.4.3 Transmitter Electrical Data .....	2-5
2.4.4 Additional features .....	2-5
2.5 Units and Accessories supplied .....	2-6
2.6 Accessories required, but not supplied .....	2-6
2.7 Summary of the FSG 70-System .....	2-7
<b>Section III, Installation .....</b>	<b>3-1</b>
3.1 General .....	3-1
3.2 Pre-installation Check .....	3-1
3.2.1 Matching the Microphones .....	3-2
3.2.2 Audio Sidetone .....	3-2
3.3 Mechanical Installation .....	3-4
3.3.1 Installation of the Transceiver .....	3-4
3.3.2 Influence on Compass .....	3-4
3.3.3 Antenna Installation .....	3-7
3.4 On-board Wiring .....	3-8
3.4.1 General Instructions for On-Board Wiring .....	3-8
3.4.2 Connection of the microphones .....	3-12
3.4.3 Intercommunication (IC) .....	3-12
3.4.4 Speaker/Phone connection .....	3-12
3.4.5 AF-External Input .....	3-12
3.4.6 Illumination of the Frequency Display .....	3-13
3.4.7 Connection to 28Vdc aircraft bus .....	3-13
3.5 Post Installation Check .....	3-14
3.5.1 Testing on the Ground with the Engine Off .....	3-14
3.5.2 Testing on the Ground with Engine Running .....	3-14
<b>Section IV, Operation .....</b>	<b>4-1</b>
4.1 Control Functions .....	4-1
4.2 Operating Instructions .....	4-2
4.3 Programming the Channel Frequency Memory (FSG 71M only) .....	4-3
4.4 Recall of Stored Frequencies .....	4-3
4.5 Battery Check .....	4-3
4.6 Emergency Operation .....	4-4
4.7 Squelch Function (SQ) .....	4-4
4.8 Intercommunication (IC) .....	4-4
4.9 Audio External .....	4-4
<b>Appendix A, Certificate .....</b>	<b>A-1</b>

## List of illustrations

Figure	Page
3-1 Location of Audio Sidetone Control and Microphone Gain Control.....	3-2
3-2 Test Set-up, Envelope Detector .....	3-3
3-3 Deviation of Compass by FSG 70/FSG 71M depending on the Distance between Center of Compass and Contour of Transceiver .....	3-4
3-4 FSG 70, Dimensions, Installation Drawing.....	3-5
3-5 FSG 71M, Dimensions, Installation Drawing.....	3-6
3-6 Connector Assembling, Sliding Lock Assembly .....	3-8
3-7 FSG 70/FSG 71M, Hook-up Diagram without INTERCOM, 1-2 Dynamic Microphones.....	3-9
3-8 FSG 70/FSG 71M, Hook-up Diagram using wire harness F10029, 1-2 Dynamic Microphones and INTERCOM .....	3-10
3-9 FSG 70/FSG 71M, Hook-up Diagram, 1-2 Standard Carbon Microphone/s and INTERCOM .....	3-11
3-10 Activating the AF EXTERNAL Input .....	3-13
4-1 Controls and Readouts.....	4-1

## List of valid pages

Page	Effective Date	Page	Effective Date
Title page	July 1998	3 - 4	July 1998
ii	July 1998	3 - 5	July 1998
iii	July 1998	3 - 6	July 1998
iv	July 1998	3 - 7	July 1998
1 - 1	July 1998	3 - 8	July 1998
1 - 2	July 1998	3 - 9	July 1998
2 - 1	July 1998	3 - 10	July 1998
2 - 2	July 1998	3 - 11	July 1998
2 - 3	July 1998	3 - 12	July 1998
2 - 4	July 1998	3 - 13	July 1998
2 - 5	July 1998	3 - 14	July 1998
2 - 6	July 1998	4 - 1	July 1998
2 - 7	July 1998	4 - 2	July 1998
2 - 8	July 1998	4 - 3	July 1998
3 - 1	July 1998	4 - 4	July 1998
3 - 2	July 1998	A - 1	July 1998
3 - 3	July 1998		

## Section I **Safety Information**

Every radio, when transmitting, radiates energy into the atmosphere that may, under certain conditions, cause the generation of sparks. All users of our radios should be aware of the following warning:

**Do not operate this radio in an explosive atmosphere (petroleum fuels, solvents, dust, etc.)!**

During normal use, the radio will subject you to radio frequency energy substantially below the level where any kind of harm is reported.

**TO ENSURE PERSONAL SAFETY**, please observe the following simple rules:

- **DO NOT** transmit when the antenna is very close to, or touching, exposed parts of the body, especially the face and eyes.
- **DO NOT** transmit on a busy channel.
- **DO NOT** press the transmit (PTT) key when not actually desiring to transmit.
- **DO NOT** transmit in closed aircraft or vehicles with the antenna inside the cabin. This may cause malfunction of the avionics or trigger the airbag! Always operate the radio **FSG 70/71M** with a suitable outside / external antenna! Assure appropriate lightning protection where elevated outdoor antennas are used.
- **DO NOT** operate the radio whilst driving. It should also be noticed that the use of a hand held microphone while driving could constitute an offence under the Road Traffic Regulations in certain countries.
- **DO NOT** allow children to play with any radio equipment containing a transmitter.
- Always switch OFF the radio first when installing the unit into vehicles, aircraft or carrier cases or when removing from it!
- Always switch OFF the radio first when starting an engine or vehicle!
- When operating the **FSG 70/71M** on a 24/28Vdc source a suitable Voltage Converter 24Vdc/12Vdc of at least 4 Amps must be used!
- The **FSG 70/71M** may be used exclusively for communication on the airband frequencies.
- Unauthorized modifications and changes of the system **are forbidden**.
- When replacing defective parts use only original spare parts or standard parts recommended by the manufacturer!
- In aircraft or vehicles a suitable noise canceling microphone or headset for aircraft radios shall be used.
- A backup microphone should always be carried during any flight. Even new microphones can fail.
- Volume is very important. Increasing speaking levels while the lips are facing the microphone, but not straining or pushing to yelling levels will increase clarity.
- Prior to any flight verify proper **FSG 70/71M** functions by means of a short communications test. It has to be taken into account that with a faulty antenna or cable this COM test may absolutely turn out positive at the airfield or in short distance to the ground station. But at a distance of 2 to 6 miles faulty antenna and/or cables will cause communication breakdown!
- Push-to-Talk keys may stick occasionally. Therefore, observe while transmitting the yellow TX LED at the **FSG 70/71M**. This TX LED must go off when releasing the PTT key.
- Replace blown fuse only against correct type with specified nominal value. Investigate the cause.

## 1.1 Used Symbols

In this manual the following symbols are used:



**DANGER!**

*describes an immediate threatening danger! Failing to observe the note may cause death or heavy injuries!*



**CAUTION!**

*describes a special note for operation. Failing to observe the note may cause damage of the transceiver and/or stored data may be deleted (user programmed memory)!*



**IMPORTANT!**

*describes explanations and other useful hints. Failing to observe the note may cause degraded performance and/or unsatisfying operation!*

## Section II      **General Information**

### **2.1      Introduction**

This installation and operation manual, 027.HB.00E, contains instructions and descriptions for application, installation and operation of the **FSG 70** and **FSG 71M** 760-channel VHF aircraft transceivers of WALTER DITTEL GmbH's **FSG 70-SYSTEM**.

The Service Manual 027.HB.10 contains detailed circuit description, repair instructions, alignment procedure, testing instructions, and a detailed Illustrated Parts List.

### **2.2      Application**

The transceivers of the **FSG 70-System** are fully transistorized VHF radios of monoblock construction for two way voice communications within the extended frequency range of 118.00 MHz to 136.975 MHz in 25 kHz increments (760 channels). The equipment is well suited for reciprocating, turbopropeller or turbojet engine aircraft as well as for helicopters with reciprocating or turbojet engines. The equipment comply with applicable RTCA Performance Standards (observe national regulations).

Featuring small dimensions, low weight and extremely low current consumption, these units are suitable in motorized gliders, gliders, balloons, Ultralights, homebuilts, experimentals and as emergency back-up transceiver too.

Together with the W. Ditttel GmbH carrying cases the transceivers of the **FSG 70-SYSTEM** can be used as portable, mobile and fixed base ground stations. The excellent suitability of the units to be powered by batteries should be emphasized. Special modes like Intercom, AF-External Input, storage of VHF-frequencies etc. are possible without any other additional equipment (depending on type of unit).

The LC-frequency display can be illuminated.

The transceivers comply with the Performance Standards of RTCA- and EUROCAE-regulations. Additionally they comply with the regulations for groundstations.

## 2.3 Brief Description

The **FSG 70** and **FSG 71M** are miniaturized lightweight panel mounted transceivers designed to operate in the VHF-COM frequency range from 118.000 to 136.975 MHz in 25 kHz increments, thus providing 760 channels over a standard communication distance of 100 nautical miles at FL 70.

The case dimensions fit into a standard 2¼" cut-out of the instrument panel. Only four screws (M 4 x 16) are used to install the transceiver units. Electrical connections to the environment are made through a 15-pole SUB-D connector and a BNC female connector at the rear panel of the units.

The operational frequency is displayed by means of a Liquid Crystal Display with five digits following the ICAO-scheme:

The least significant digit is omitted (e.g. 127.875 is displayed as 127.87 MHz).

The transceivers consist of five main sections: Digital frequency synthesizer, receiver, transmitter (6 watts carrier, 24 watts PEP), audio circuits, and LCD frequency display circuitry.

Model **FSG 71M** includes an additional section:

A non volatile electronic ten channel memory. This memory and its command controls make the only difference between **FSG 70** and **FSG 71M**. The operational frequency of the **FSG 71M** unit is indicated by the LCD and may be selected in two modes on the front panel:

- a) **Direct mode:** The channel control knob on the right front side must be set to full ccw position. By using the MHz/kHz coaxial double knob on the front panel all 760 channels may be selected as usual.
- b) **Storage mode:** The channel control knob is set to select the desired channel for any "Read" or "Store" action. Up to 10 out of 760 channels may be programmed and permanently stored for up to five to six years in the electronic memory. Storage channels may also be reprogrammed if necessary, even in flight.

The **FSG 70** has no channel control. Frequency selection can be performed only in direct mode using the coaxial double knob.

Further features incorporate an automatic squelch circuit with manual override and automatic adaptation to pulsed noise, separate microphone inputs for low level dynamic and standard carbon mikes, compressor for modulation level control, a "transmitter ON" annunciator LED, an intercom mode, a wide supply voltage range of 9.7 to 15.2Vdc, audio lowpass filter for CLIMAX environment, additional AF input for application of external (e.g. NAV-) audio, internal lighting of the frequency display and a very comprehensive indication of "Low Supply" by flashing of the frequency display. Audio output is delivered separately for speakers (receive only) and for headphones (receive and transmit sidetone).

The transceivers can be supplied either direct from 12/14Vdc-buses or via a voltage converter (Type S20000) from 28Vdc-buses.

An automatic power-saving circuit prevents unnecessary power consumption in some operating modes, thereby extending the operating time available from one battery charge. Particularly the no-signal current drain in the squelch (SQ) mode is reduced to the very low level of approx. 25 mA.



## 2.4 FSG 70-System Technical Data

### 2.4.1 General Data

Model:	<b>FSG 70/FSG 71M</b>
Operating voltage:	13.8Vdc +10% / -20%
Emergency operation:	9.7Vdc to 11Vdc
Power consumption:	Stand by: 27mA (typical) Intercom: 85mA (typical) Receive (voice): 140mA (typical) Transmit (voice): 1.5A (typical) Illumination: 20mA additional
Recommended fuse:	2.5 Amp semi time lag acting
Temperature range:	-20°C to +55°C, short-term +71°C
Storage Temperature:	-55°C to +85°C
Altitude capability:	15,000m/50,000ft. MSL
Vibration stability:	0.1", 5 - 27Hz / 1.5g, 27 - 500Hz / 1g, up to 2000Hz
Front panel dimensions:	Ø 57.2mm corresponds to 2¼" cut-out
Installation depth (measured from rear of panel):	191mm + approx. 50mm for plug and wires
Overall dimensions:	W = 63mm, H = 61mm, D = 237mm
Weight:	<b>FSG 70:</b> 0.74kg/1.6lb <b>FSG 71M:</b> 0.80kg/1.76lb
Equipment category according to RTCA DO-156:	Class C
RTCA DO-157:	Class 4
Performance category according to DO-160 A:	D1/A/MNO/XXXXXXXXZBABZ

**The radios FSG 70 and FSG 71M fulfil the technical requirements of ICAO Annex 10, immunity against FM Broadcast Interference.**

## 2.4.2 Receiver Electrical Data

Receiver type:	Single superheterodyne
Frequency range:	118.000MHz to 136.975MHz
Number of channels ( <b>FSG 70</b> ):	760
Number of channels ( <b>FSG 71M</b> ):	760, of which 10 frequencies may be free programmed and permanently stored
Channel spacing:	25kHz
Sensitivity:	$\leq 1.0\mu\text{V}$ for 6dB (S+N)/N, 50 Ohms, mod. 1000Hz/m = 30 %
Bandwidth:	$> \pm 8\text{kHz}$ at 6dB
Selectivity:	$\geq 70\text{dB}$ at $\pm 25\text{kHz}$ ; $\geq 40\text{dB}$ at $\pm 17\text{kHz}$
Squelch:	Automatic, defeatable, threshold internally adjustable ca. 0.5 - 3 $\mu\text{V}$
Gain control:	$\leq 6\text{dB}$ (5 $\mu\text{V}$ to 200mV)
Spurious response:	$\geq 80\text{dB}$ (image); $\geq 75\text{dB}$ (others)
Spurious radiation:	$< 5 \times 10^{-11}$ Watt
Distortion, m = 85%:	$\leq 10\%$
Frequency response:	$\leq 6\text{dB}$ , 350 to 2,500Hz $\geq 18\text{dB}$ at 4,000Hz
Intermediate frequency:	10.0MHz
Rated output:	Headphone 35mW into 500 $\Omega$ , adjustable Loudspeaker 8W into 2 $\Omega$ 4W into 4 $\Omega$

### 2.4.3 Transmitter Electrical Data

Frequency range:	118.000 to 136.975MHz
Number of channels ( <b>FSG 70</b> ):	760
Number of channels ( <b>FSG 71M</b> ):	760, of which 10 frequencies may be free programmed and permanently stored
Transmitter output:	Min. 6 Watt into 50 Ohms at nom. voltage
Type of modulation:	Amplitude modulation (6A3)
Operation:	Simplex (SCS)
Depth of modulation:	Max. 95%
Modulation limiting:	Adjustable control
Frequency deviation:	$< 15 \times 10^{-6}$
Harmonic and spurious radiation:	$< 2 \times 10^{-7}$ Watt
Harmonics and spurious in the range of:	
108 to 118 MHz	$< 2 \times 10^{-9}$ Watt
1015 to 1045 MHz	$< 2 \times 10^{-9}$ Watt
Frequency response:	$\leq 6$ dB, 350 to 2,500Hz
Distortion factor, m = 85%:	$< 10\%$
Modulation S/N ratio:	$> 35$ db
Adjacent channel rejection:	$\geq 70$ dB at 1,250Hz, m = 60% + 10dB
Microphone input for m = 85%:	
a) Low level input:	1 to 10mV into 200 $\Omega$ , adjustable
b) High level input:	100 to 1000mV into 200 $\Omega$

### 2.4.4 Additional features

Display lighting:	+14Vdc; 28Vdc by order or external resistor 680 Ohms/0.5 Watt.
External audio input:	Min. 1.0V into 470 Ohms for rated performance.
Intercom:	Through microphone input, activated by grounding.
RX audio annunciator:	Logic HIGH (+10Vdc) in Receive and NO SIGNAL mode. Otherwise logic LOW (0Vdc).

## 2.5 Units and Accessories supplied

	Article No.
<b>FSG 70</b> .....	F10002
incl. Installation Manual and 4 fixing screws	
<b>FSG 71M</b> .....	F10003
incl. Installation Manual and 4 fixing screws	

### Optional Accessories

Installation Manual, <b>FSG 70/FSG 71M</b>	027.HB.00E
Maintenance/Overhaul Manual <b>FSG 70/FSG 71M</b>	027.HB.10
Prefabricated cable assemblies on stock!	

For additional accessories, please request our equipment recommendations and price lists for the **FSG 70-System**.

## 2.6 Accessories required, but not supplied

- a) VHF aviation communications antenna, cable, and BNC-Plug
- b) Headphone/s (approx. 300 Ohms) and/or loudspeaker/s (2 to 16 Ohms)
- c) Dynamic microphone/s (200 Ohms), dynamic microphone/s with pre-amp, or low impedance carbon microphone/s with/without push-to-talk button (two separate microphone inputs).
- d) Alternate to b) and c) headset with above specifications.
- e) Battery power-pack 12Vdc/6.5Ah, if no on-board supply system
- f) Push-to-talk button for installation on control stick.
- g) To operate the **FSG 70/FSG 71M** on a 28-V on-board supply, a suitable voltage regulator must be used.
- h) 15-pole Plug, type DA-15S incl. shell, if no complete cable assembly is ordered.

## 2.7 Summary of the FSG 70-System

In Table 2-1, the various types of VHF COM transceiver of the FSG 70 System are listed.

The Part-No. is printed on the type plate of the respective transceiver.

Part-No.	Article-No	Type	Frequency Memory	Frequency Range MHz	Lighting Voltage
027/111	F10002	FSG 70	no	118 - 136.975	14Vdc
027/112	F10099	FSG 70	no	118 - 136.975	28Vdc
027/131	Ceased Production	FSG 70	no	118 - 135.975	14Vdc
027/132	Ceased Production	FSG 70	no	118 - 135.975	28Vdc
028/121*	Ceased Production	FSG 70	no	118 - 157.975*	14Vdc
028/122*	Ceased Production	FSG 70	no	118 - 157.975*	28Vdc
027/211	F10003	FSG 71M	yes	118 - 136.975	14Vdc
027/212	F10100	FSG 71M	yes	118 - 136.975	28Vdc
027/231	Ceased Production	FSG 71M	yes	118 - 135.975.	14Vdc
027/232	Ceased Production	FSG 71M	yes	118 - 135.975	28Vdc
028/221*	F10102	FSG 71M	yes	118 - 157.975*	14Vdc
028/222*	Ceased Production	FSG 71M	yes	118 - 157.975*	28Vdc

Table 2-1

\* Extended frequency range for Government Authorities only.

THIS PAGE  
INTENTIONALLY  
LEFT BLANK

## Section III Installation



### **IMPORTANT!**

- **Switch always OFF the radio before connecting or disconnecting the receptacle plug! This is a simple precaution which helps to protect the solid state circuitry and extends the operating life of your avionics equipment.**

### 3.1 General

This section contains instructions and suggestions for installing the **FSG 70/ FSG 71M** in an aircraft.

### 3.2 Pre-installation Check

Carefully remove the transceiver packing and save in case a claim has to be placed with the shipper.

Check for conformity between delivery note and goods delivered. Check the unit carefully for external damage. Before installing, a check of the main functions is recommended:

1. Connect the unit to a test bench, using the test cable set (shown in Fig. 3-2). Ensure 13.8Vdc operating voltage, and switch on the unit (right toggle switch "ON"). SQ-switch "OFF" (left toggle switch down).
2. Turn volume control about half-way open (clockwise). Slight receiver noise should be audible on all channels in the range from 118 to 136.975 MHz. Receiver sensitivity should be equal the technical data on all channels (check by sample test).
3. Push left toggle switch upward (SQ), vary VHF generator output voltage and observe the squelch threshold; it must be between 0.5  $\mu$ V and 3  $\mu$ V (depending on setting).
4. Connect RF test set-up with RF load resistor (50 Ohms) at the antenna output. Transmit and measure the output power ( $\geq 6$  W).
5. Connect 1.000-Hz audio generator through a voltage divider or directly (low level/high level microphone) to the microphone input.

#### **a) High level input (Standard Carbon mike)**

With an AF input voltage of approx. 100 mV<sub>eff</sub> the transmitter should be > 40% modulated. Raise the AF input voltage to 1.0V. Observe the envelope; a continuous over-modulation must not occur. The depth of modulation must not exceed 95%.

#### **b) Low level input (Dynamic microphone)**

With an AF input voltage of approx. 1mV<sub>eff</sub> the transmitter should be > 40% modulated. Raise the AF input voltage to 10mV. Observe the envelope; the depth of modulation must not exceed 95%.



### **IMPORTANT!**

- With voice modulation, greater depths of modulation occur because of the dynamics typical of speech (quick level changes). Setting the modulation control to approx. 85% (for sine modulation) results in a favorable compromise between carrier utilization and over-modulation.

### 3.2.1 Matching the Microphones

The output voltages of dynamic microphones are differing reasonably depending on type, number of parallel connected microphones, and speech volume.

To utilize the high quality of our transceivers, we recommend matching of the microphone-set in use to the microphone input of the transceiver as follows:

- a) Connect the microphone-set (max. 2 microphones of the same type) via test cable or on-board wiring to the transceiver.
- b) Turn microphone gain potentiometer (see Fig. 3-1) fully ccw. Set sidetone level control to any position (except the full ccw position) and check the headphone output level.
- c) Switch ON Intercom. Talk into one of the microphones with typical loudness and distance. Adjust microphone gain potentiometer cw, until no more increase of the amplitude on the CRT is visible (control threshold). Check both microphones, they should have the same adjustment.
- d) Secure microphone gain potentiometer by any staking lacquer.



**IMPORTANT!**

- a) The speech volume of course is higher in a noisy powered glider or in an Ultralight than in a silent fiberglass glider.
- b) For standard carbon microphones no matching is required, but they should be checked in the way mentioned.

### 3.2.2 Audio Sidetone

With the **FSG 70/FSG 71M** transceiver, a part of the modulation signal is fed to the headphone output as long as the transmitter is operated. The sidetone control (see Fig. 3-1) should be set so that the tone is audible, but not too loud. Please consider the ambient noise in the aircraft when adjusting.

The volume in Intercom mode is about the volume of the audio sidetone and can not be adjusted separately.

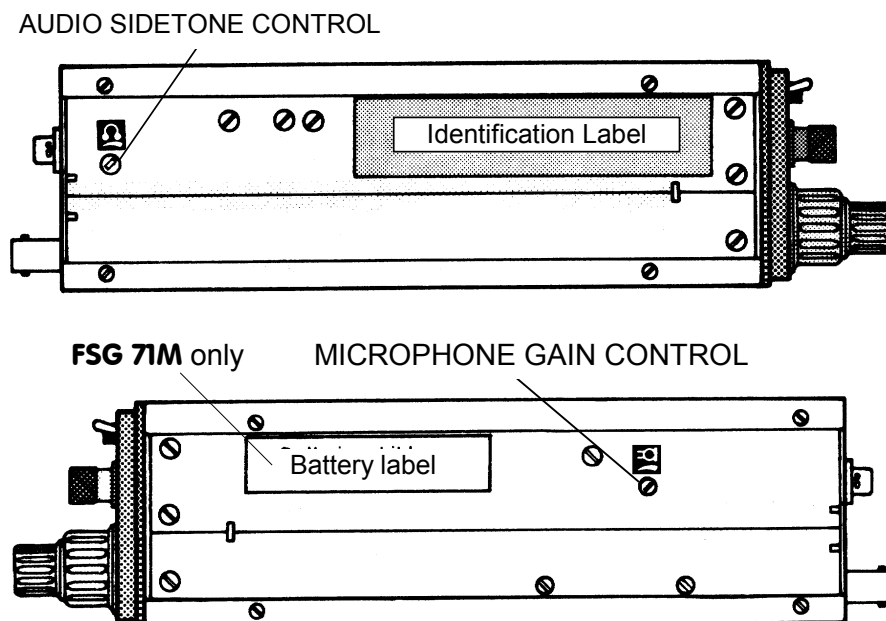
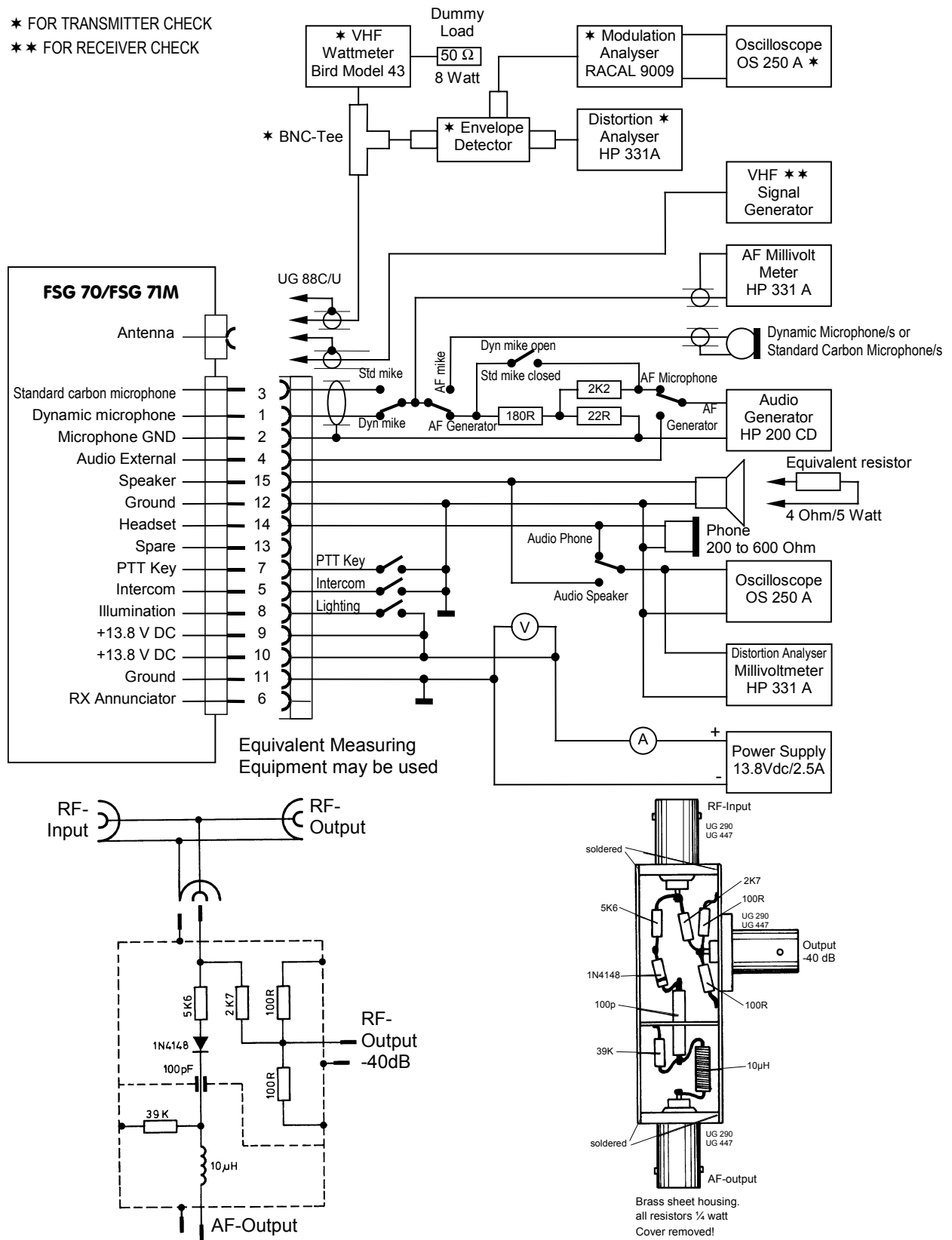

Fig. 3-1 Location of Audio Sidetone Control and Microphone Gain Control



\* FOR TRANSMITTER CHECK  
\*\* FOR RECEIVER CHECK



**Fig. 3-2 Test Set-up  
Envelope Detector**

### 3.3 Mechanical Installation

#### 3.3.1 Installation of the Transceiver

The units of the **FSG 70 System** are rigid mounted behind the aircraft's panel. They fit into a standard 2¼" cut-out. If there is no suitable cut-out, one can be made following the drawing Fig. 3-4 or Fig. 3-5.

To install the transceiver in the instrument panel, select a location which is as far as possible from heat sources, but which can be seen easily and reached by the pilot and co-pilot. Ensure that there is adequate space for installation of cables and connectors. The unit is fixed to the panel by four pan head screws M 4 x 16 (supplied). The length of the screws is sufficient for panel thickness' between 2 and 8 mm.

#### 3.3.2 Influence on Compass

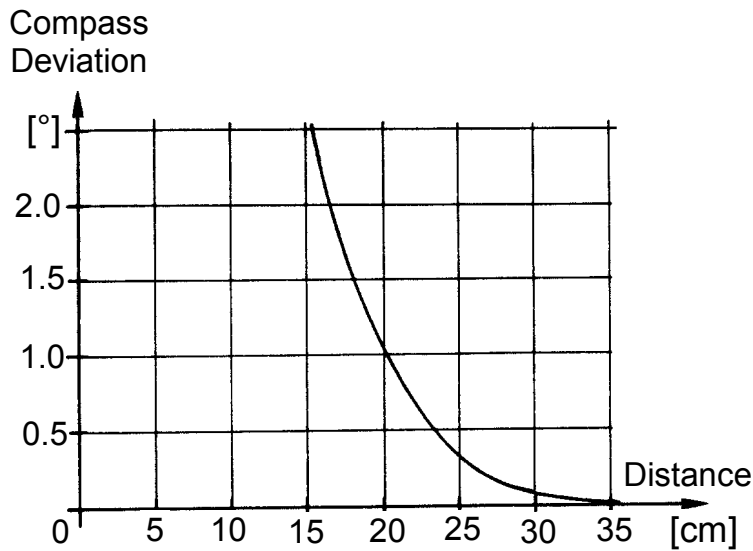
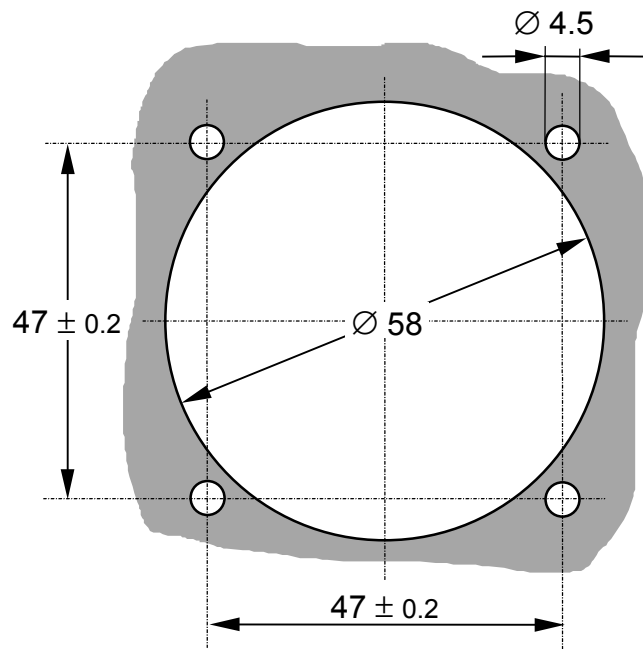
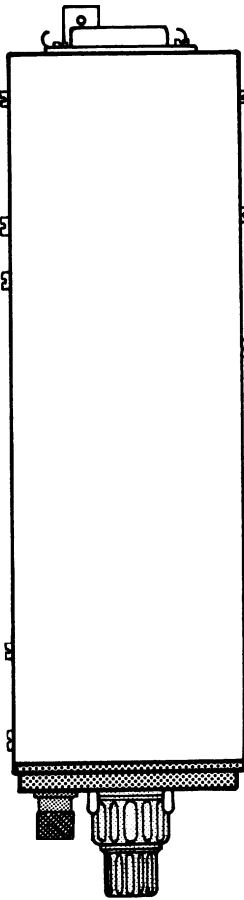
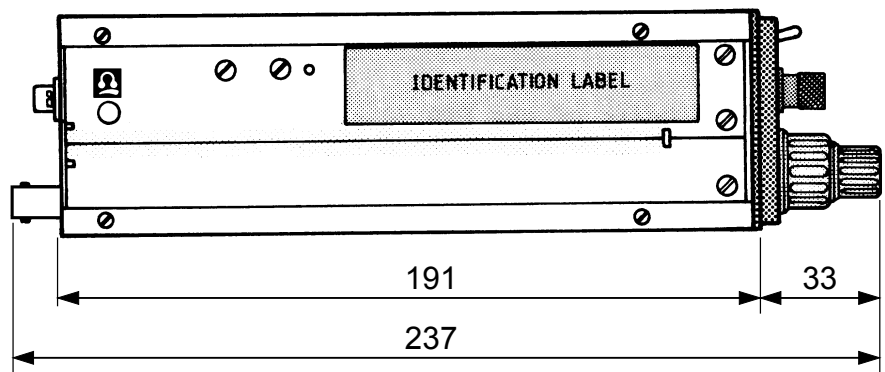
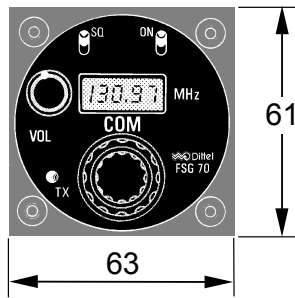
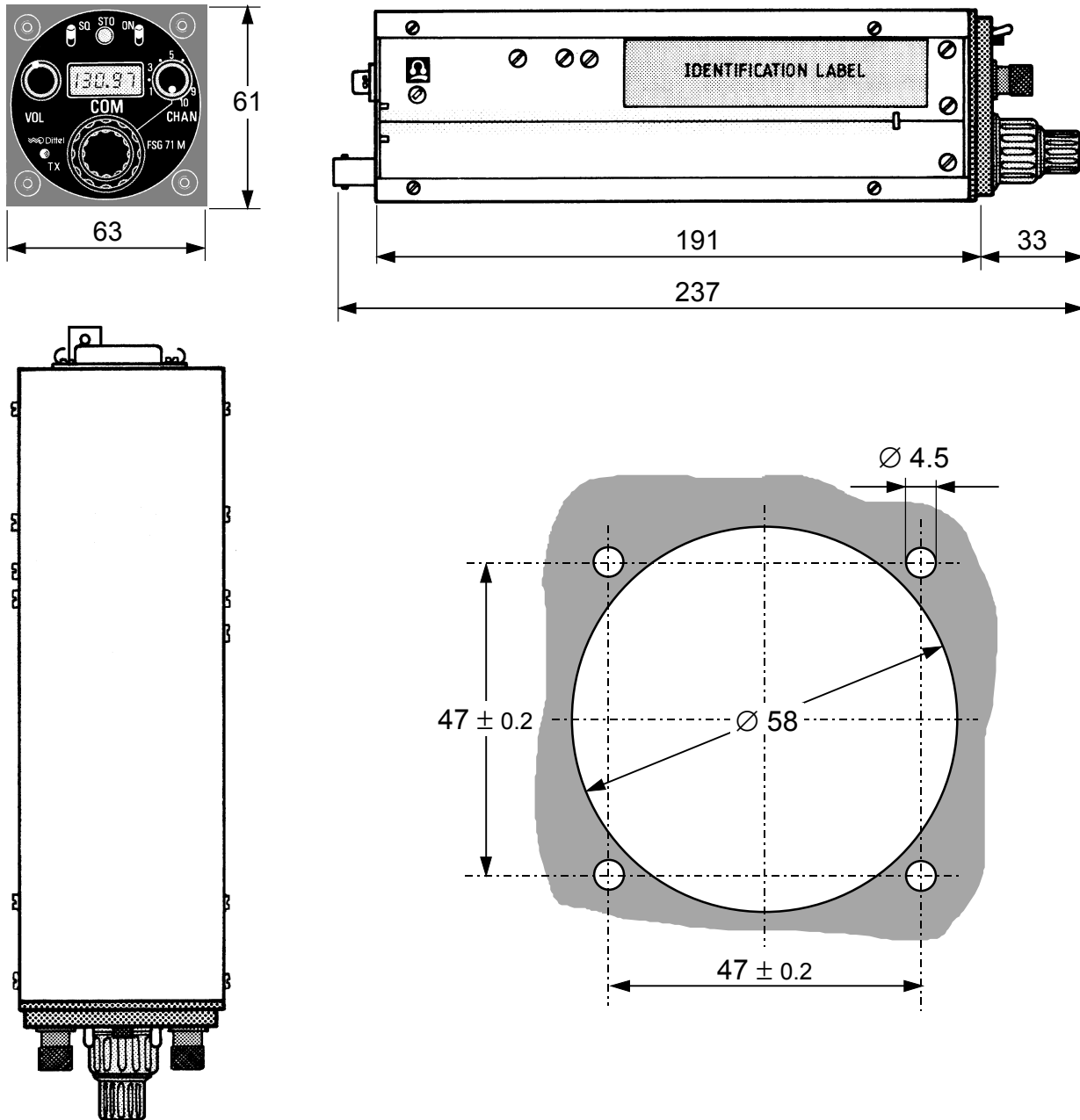

Fig. 3-3: Deviation of Compass by **FSG 70/FSG 71M** depending on the Distance between Center of compass and contour of Transceiver



All dimensions in Millimeter  
 Weight: 0.74 kg

**Fig. 3-4 FSG 70**  
**Dimensions**  
**Installation Drawing**



All Dimensions in Millimeter  
Weight: 0,8 kg

Fig. 3-5 FSG 71 M  
Dimensions  
Installation Drawing

### 3.3.3 Antenna Installation

A conventional 50 Ohm vertically polarized COM antenna is required with the **FSG 70/FSG 71M** transceivers. The antenna must be able to radiate equally distributed RF energy without interference.

For installation in an aircraft with a metal fuselage, we recommend our AV-529 antenna (part No. ZT 037), for wooden and plastic aircraft, our swiveling aviation communications antenna with four aluminum ground plane strips (ZT 008) and for aircraft with vertical tail rudder of non-conductive material (Notice: carbon fiber is conductive and screens the antenna), our folded top antenna (to be installed in vertical rudder during rudder manufacturing. Installation drawing available on request.).

The location for the antenna must be carefully selected, and the installation instructions must be followed exactly if optimal results are to be expected.

- The antenna should be mounted vertically on or under the fuselage such that it is well removed from any projections that may shield RX and TX such as propeller/s, landing gear or rudders.
- The distance to other antennas, e.g., COM, NAV, etc. should be at least 1.5 meter. If two units of FSG 50, FSG 60/60 M, 70/71M are used, a distance of one meter is sufficient.
- The area of installation should be flat as far as possible around the antenna.
- The metal-to-metal contact between the aircraft's surface and the antenna must be very good. For aircraft with non-metallic surfaces, metal foil (80 x 80 cm, min.) is to be glued to the interior of the fuselage or four crossed strips of sheet metal are to be installed (see above: aviation communications antenna with aluminum ground plane). The ground plane must be bolted directly at the foot of the antenna (conductive connection).
- With thin fuselage skin, the mounting hole must be suitably reinforced. All breaches of the exterior skin are to be carefully closed with sealant. This step may not degrade the electric contact.
- When routing the antenna cable, sharp bends and unnecessary length are to be avoided.
- Installation of a folded-top antenna in the vertical tail rudder is to be made by the aircraft's manufacturer.

### 3.4 On-board Wiring

Figures 3-7 to 3-9 show possible ways of connecting the **FSG 70/FSG 71M**.

#### 3.4.1 General Instructions for On-Board Wiring

- Ensure good electrical contacts and interference suppression of all parts of the electrical system, e.g., alternator, ignition system, etc., also check for influences of vibration and corrosion.
- Connecting wires are to be placed as far as possible from other wires carrying large currents, antenna lines, etc., as well as control wires, control cables, etc. Keep power lines at least 15 cm from the compass.
- Use self-extinguishing wires designed for at least 600 V (complying with MIL-W-5086C or MIL-W-16878D). Use only stranded wire to avoid broken wires caused by vibration.
- The suggested cross sections should be kept.
- Ground loops must be avoided.
- The wires are soldered to the connector DA-15S. Isolate the joints by shrinking sleeves or rubber tubes.
- The transceivers are only protected against wrong polarity, if a suitable fuse is installed. We recommend a semi time lag acting fuse 2.5 A or an automatic circuit breaker 2.5 Amp.
- If no suitable fuse is installed the units can be damaged and no guarantee claim will be accepted.
- Assemble connector according Fig. 3-6, do not crush any wires.
- Before plugging the connector to the unit check carefully the wiring, particularly the (+) and (-) wiring.
- After plugging secure the connector against loosening by pushing the sliding lock retainer.
- For easy on-board wiring (only pin and socket connectors) we have prefabricated cable assemblies on stock.

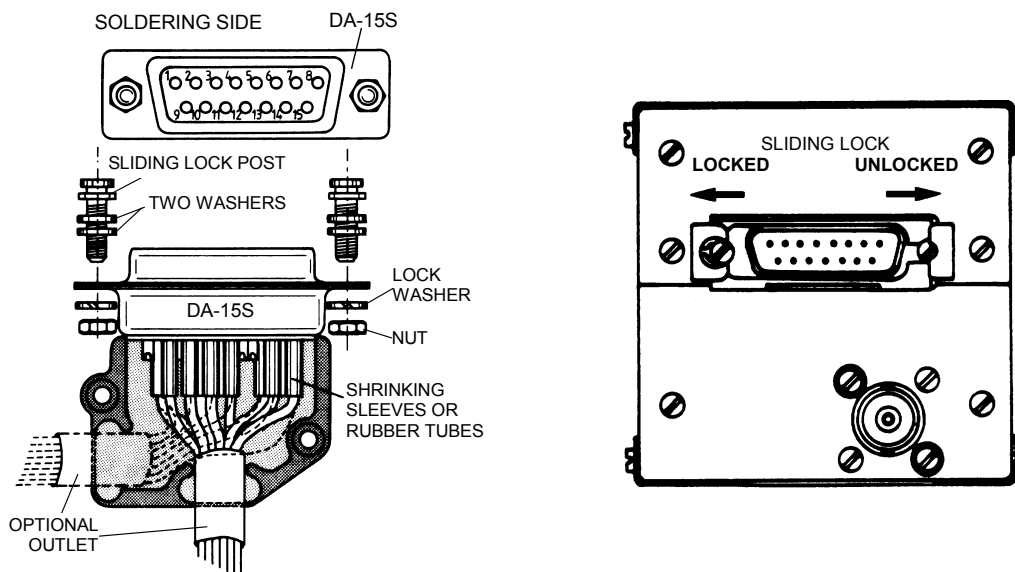

**Fig. 3-6: Connector Assembling  
 Sliding lock Ass'y**

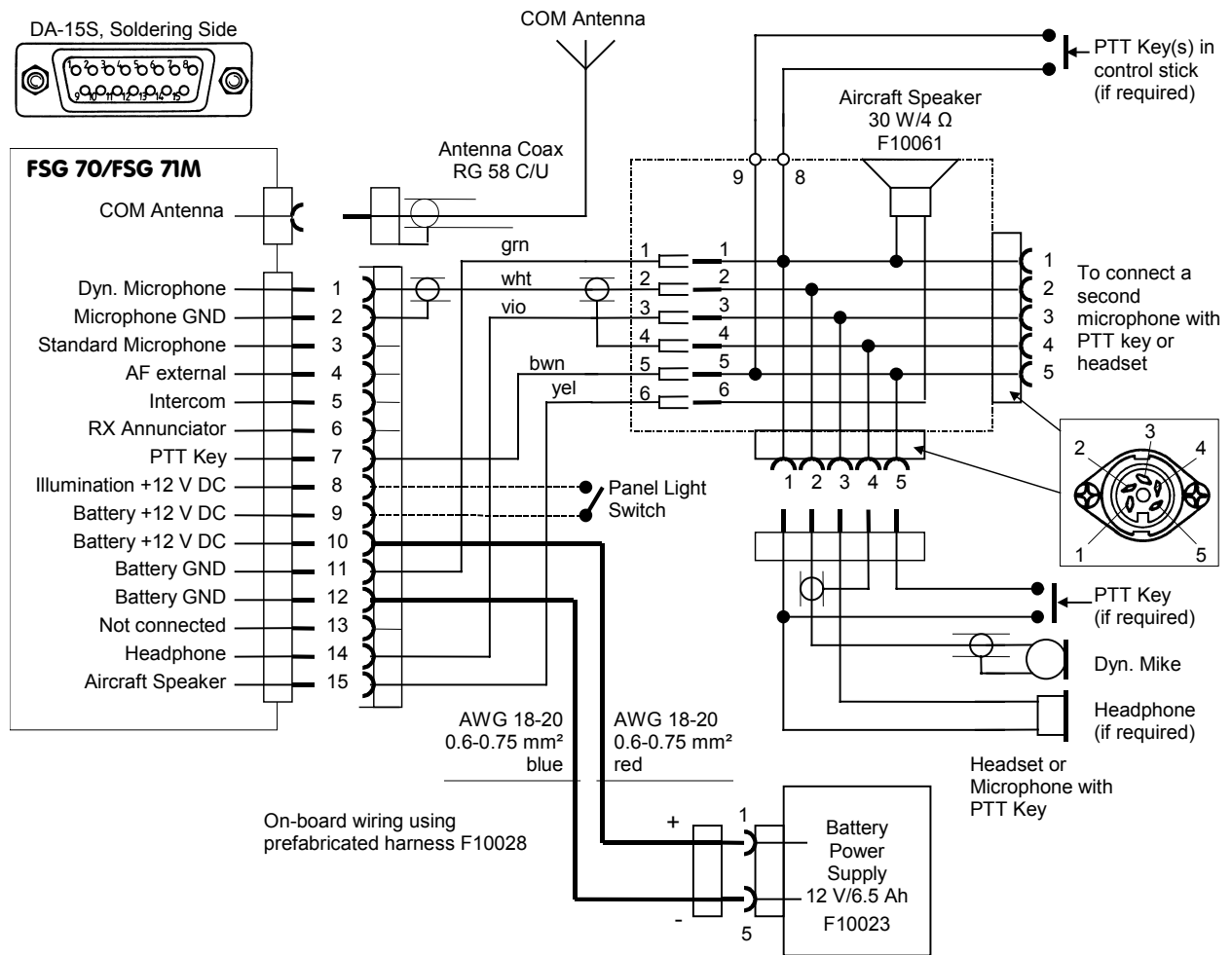

**NOTES:**

**DO NOT** wire other pins than noted!

All wires #22 AWG (0.3 - 0.4 mm<sup>2</sup>) unless otherwise noted

Built-in Automatic Circuit Breaker when using Battery Power Supply F10023

Length of pre-fabricated wire harness F10028: 3.2m / 9.5ft

----- and coax antenna cable are **not** included in wire harness F10028

**Fig. 3-7 FSG 70/FSG 71M**  
**Hook-up Diagram without INTERCOM**  
**1 - 2 Dynamic Microphones**

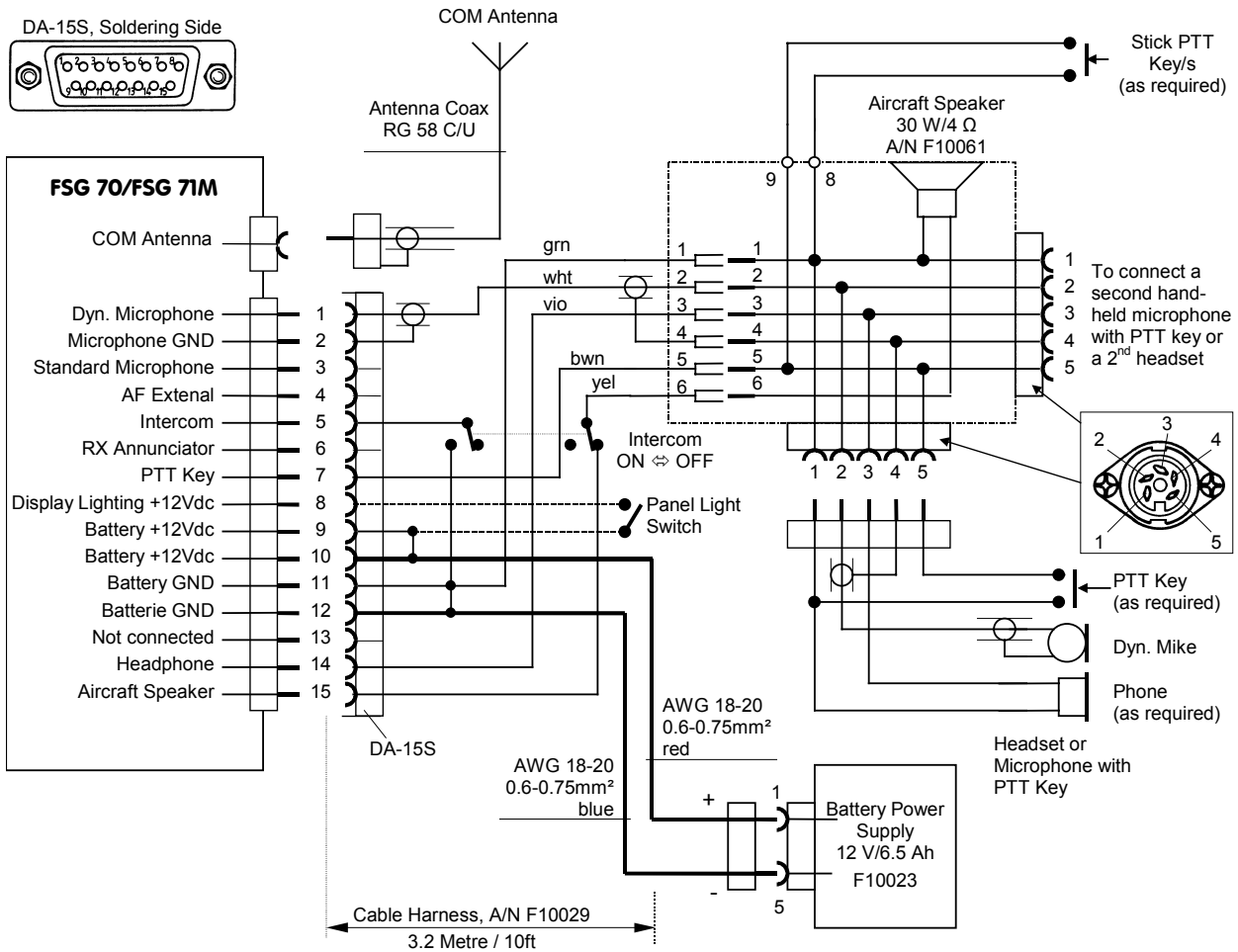

**NOTES:**

**DO NOT** wire other pins than noted!

Unless otherwise noted, all wires #22 AWG (0.3 - 0.4 mm<sup>2</sup>)

INTERCOM operation requires a microphone which provides audio OUT with the PTT key de-energized (not keyed).

Built-in Automatic Circuit Breaker when using Walter Dittell Battery Power Supply A/N F10023.

Length of pre-fabricated wire harness F10029: 3.2m / 10ft

----- and coax antenna cable are **not** included in wire harness F10029

**Fig. 3-8 FSG 70/FSG 71M**  
**Hook-up Diagram using wire harness F10029**  
**1 - 2 Dynamic Microphones and INTERCOM**



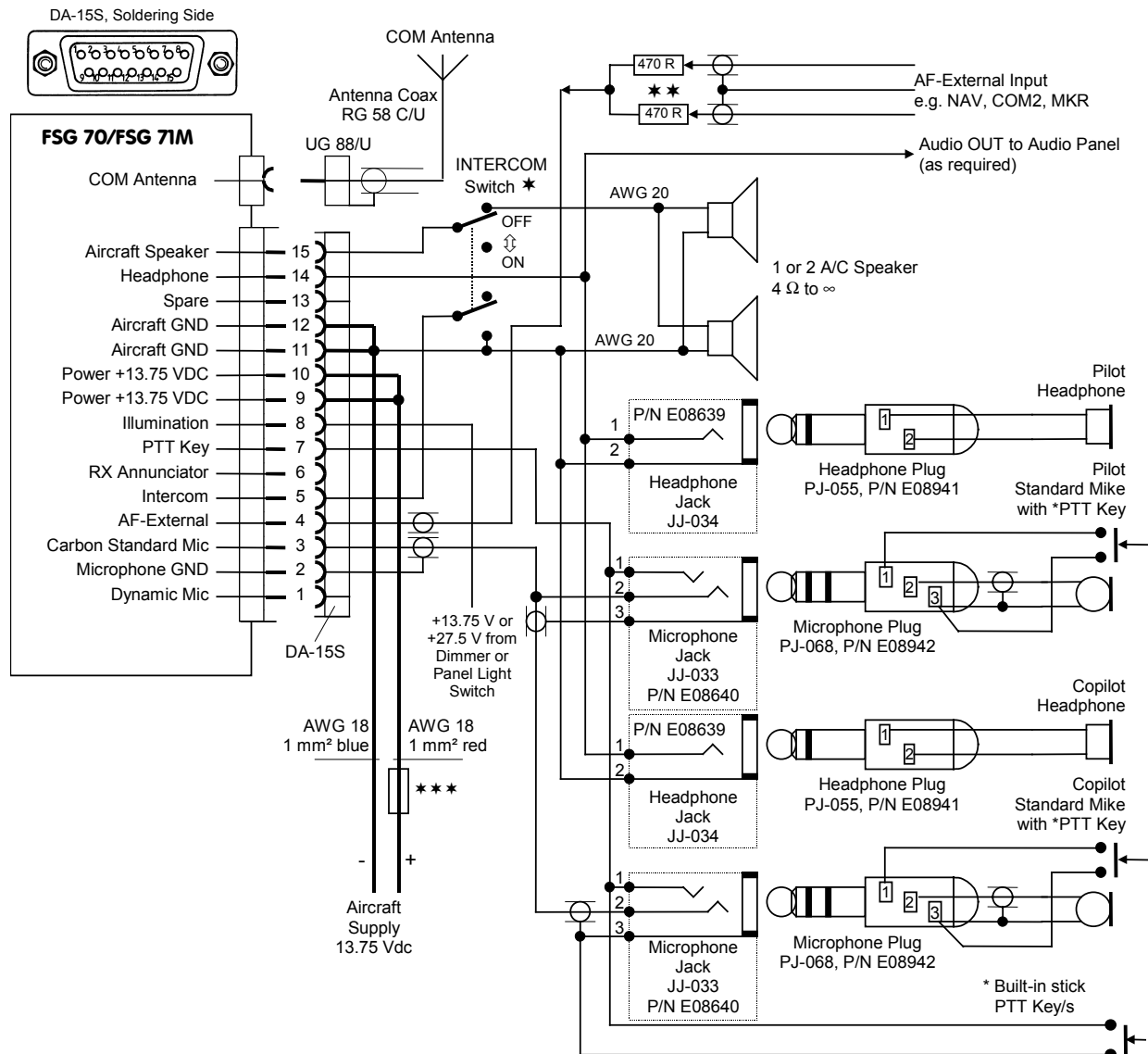

**NOTES:**

**DO NOT** wire other pins than noted!

Unless otherwise noted, all wires #22 AWG (0.3 - 0.4 mm<sup>2</sup>).

Unless otherwise noted, all Power Grounds are airframe grounds.

INTERCOM operation requires a microphone which provides audio OUT with the PTT key de-energized (not keyed).

INTERCOM operation requires a selector switch, double pole, double throw.

Terminate audio shields at one end only.

Power bus circuit breakers are to be mounted in the A/C breaker panel or instrument panel such that they will be accessible in flight and safe from physical damage.

\* PTT Key/s either at hand-held microphone/s or installed on the yoke.

\* Wiring without Intercom: connect A/C speaker direct to pins 11 and 15.

\*\* If more than one AF source, isolation resistors 470 Ohm shall be installed.

\*\*\* Fuse 2.5 Amp, semi time lag, or circuit breaker 2.5 Amp.

**Fig. 3-9 FSG 70/FSG 71M**  
**Hook-up Diagram**  
**1 - 2 Standard Carbon Microphone/s and INTERCOM**

### 3.4.2 Connection of the microphones

Standard carbon microphones and amplifier microphones as well as dynamic microphones are adaptable to the transceivers without any jumper changing or soldering work inside the unit. The input for carbon microphones is pin 3, for dynamic microphones pin 1 of the receptacle. Up to two microphones (pilot and co-pilot) can be connected. Microphones with less than 30 Ohms must be matched by a transformer. The shielding of the dynamic microphone cables must be routed separately. Please refer to Chapter 3.2.1 "Matching of microphones".



#### **IMPORTANT!**

Panel jacks of PJ 068 type may only be used in connection with carbon microphones because of the common ground for microphone and PTT key. If dynamic microphones without amp are used, a ground loop during transmit would occur and this results in unstable modulation.

### 3.4.3 Intercommunication (IC)

The intercom mode is assigned for noisy aircraft. Communication is done via headsets and requires an on-board wiring according Fig. 3-8/3-9, which includes an IC-switch. During "ON-Position" the IC-switch disconnects the speaker and activates the microphone input by connecting pin 5 of receptacle to ground.

Switching ON the IC-switch enables intercom operation and simultaneous listening to received signals (radio, NAV etc.). Keying the PTT button causes normal TX operation without having to turn off the IC-switch.

### 3.4.4 Speaker/Phone connection

Up to two speakers (4 Ohms each) can be connected to the AF-output of the unit and/or up to three headphones (ca. 300 Ohms each) can be connected to the phone-output of the unit.

If no speaker is connected, terminating is not necessary.



#### **DANGER!**

- The compass is influenced by the magnetic field of the speaker. A minimum distance of 1.3 m between our aircraft speaker (Article no F10061) and the compass should be kept.

### 3.4.5 AF-External Input

The "AF-Ext. input" (pin 4 of receptacle) is provided to connect the headphone outputs of other communications equipment. This possibility of interconnecting two or more units will be used primarily in those aircraft in which only a COM-Transceiver and a NAV receiver are installed. The headphone output of the NAV unit can then be connected directly to the AF-Ext. input of the **FSG 70/ FSG 71M** and then be heard simultaneously from one common headphone or speaker (only during receive mode possible). To connect more than one external unit isolating resistors (470 Ohms) are necessary (see Fig. 3-9).

If AF-ext. audio operation is desired, the jumper at P 303 is to be changed as shown in Fig. 3-10. This inhibits the automatic power saving circuit.

To drive the FSG AF-amplifier to its rated output, an audio input of at least 1 V<sub>eff</sub> is required (input impedance approx. 10 kOhm). The connections between COM unit and external units must be shielded.

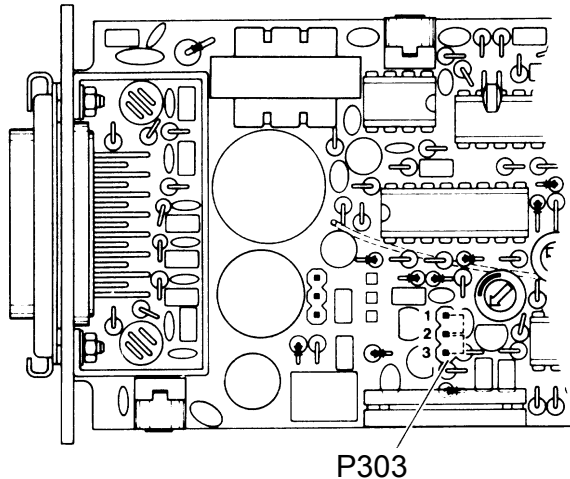

JUMPER J303 ACROSS PIN 1 + 2: FACTORY SETTING  
JUMPER J303 ACROSS PIN 2 + 3: AF-EXTERNAL

Jumper J303 is accessible after opening the upper cover.

At the **FSG 71M** the Memory P.C. Board has to be removed first.

Changing the jumper may only be performed by authorized personnel.

**Fig. 3-10 Activating the AF EXTERNAL Input**

### 3.4.6 Illumination of the Frequency Display

All transceivers of the **FSG 70-System** are equipped with an illumination of the frequency display. The lamp voltage is supplied via the aircraft's dimmer or directly from the aircraft supply. The lamp voltage is stamped on the type plate. If a 14Vdc-lighting should be connected to a 28Vdc aircraft supply, a 680 Ohm resistor (0.5 W) in series is necessary.



#### **IMPORTANT!**

- The illumination is not turned ON or OFF by the unit's ON/OFF switch. To save energy we recommend a separate lighting switch if the unit is battery powered.

### 3.4.7 Connection to 28Vdc aircraft bus

To connect the transceiver to a 28Vdc bus a suitable voltage regulator must be used. Wiring refer to Installation Manual of the Voltage Regulator.

### **3.5 Post Installation Check**

#### **3.5.1 Testing on the Ground with the Engine Off**

After installing the unit, check all aircraft control movements to be sure no electrical cables interfere with their operation.

Then measure the antenna matching between the RF jack of the unit and the antenna cable. A VHF standing wave meter or an in-line type directional wattmeter is required for this measurement.

The standing wave ratio should be less than 3:1 throughout the entire frequency range of the unit (reflected power  $\leq 25\%$  of the input power). If this value is exceeded, a strong mismatch exists which, for example, may be caused by an incorrect or insufficient ground plane, poor contacts or incorrect radiator length. For higher range we recommend a standing wave ratio of max. 2:1 (reflected power  $\leq 11\%$  of the input power).

After antenna measurement a signal check with the ground station is performed.



#### **IMPORTANT!**

- With belly-mounted COM antenna, this measurement must be performed during flight in order to prevent incorrect measurements.

#### **3.5.2 Testing on the Ground with Engine Running**

With the engine running, it must be ensured that the aircraft's electrical system voltage lies within the tolerances permitted at 14 or 28 V, as applicable; this measurement is to be made with the engine operating at cruising RPM.

When carrying out a subsequent signal check, the ground station must be at a distance of approx. one to five km. At engine cruising RPM, aircraft cabin noise should be avoided to be picked up by holding the microphone near the lips in order to provide a much more desired signal than cabin noise. If possible, verify the communications capability on both the high and low end of the VHF COM band.

If noise occurs only with the engine running and its frequency varies with the engine speed, it may be caused by an inadequately suppressed ignition system or alternator/voltage regulator equipment, or by a poorly stabilized on-board supply voltage. According RTCA 160-A the limits for ripple voltages in 14Vdc supplies are 0.79 V<sub>pp</sub> at 0.2 - 1 kHz, 1.98 V<sub>pp</sub> at 1 - 15 kHz. For 28Vdc supplies: double limits. It is easier to distinguish between RF and AF interference (carried by the lines) by removing the antenna plug at the transceiver; RF interference, which usually comes from the ignition or generating system, disappears. Supply ripple can be found with an oscilloscope. Its source is usually the generator equipment in conjunction with a poor battery or poor wiring (bad contacts, defective switches, inadequate wire cross sections, ground loops). Bad contacts in the antenna system are also responsible for heavily distorted communication.

**Section IV Operation**

**4.1 Control Functions**

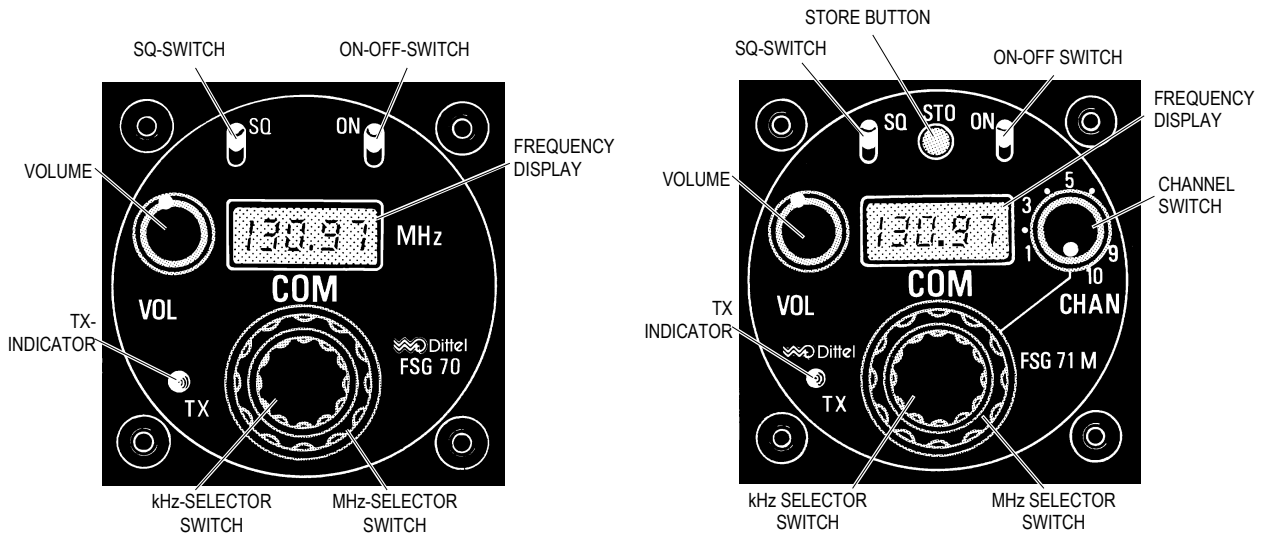

**Fig. 4-1: Controls and readouts**

Controls Readouts	Description	Function
OFF/ON	Toggle switch with two positions	Lever down: Power OFF Lever up (ON): unit supplied with power
VOL	Potentiometer	To increase the RX-volume rotate the knob clockwise.
SQ-Switch	Toggle switch with two positions	Lever down: The squelch circuit is off. Basic RX-noise is audible. Lever up (SQ): Common position, the squelch circuit is activated. Only reception of signals above SQ-threshold.
Frequency display	5-digit liquid crystal display, internal lighted	Shows the operation frequency in digital form set from 118.00 to 136.97 MHz. Last digit "5" or "0" does not appear. Blinks if power supply drops below 11Vdc.
kHz Selector	inner rotary knob with 40 detents	Sets frequency in 25 kHz increments (.000 - 975)
MHz Selector	Outer rotary knob with 19 detents (stops at 118 and 136 MHz)	Sets frequency in 1 MHz increments (118. - 136.)
TX Indicator	Yellow LED	Lights during depressing the push-to-talk switch.

Additional at <b>FSG 71M</b>		
Controls Readouts	Description	Function
CHAN Channel selector switch	Rotary knob with 11 detents	Knob fully clockwise: Frequency free selectable by MHz- and kHz knobs.  Knob on position 1 through 10: Recall or storage of channel frequencies. Refer to Section 4.3 or 4.4.
STO button	Push button	By depressing the STORE-button the displayed frequency is entered in one of the 10 electronic memories provided that the CHAN switch is at one of the 1 through 10 position.

## 4.2 Operating Instructions

Turn ON the transceiver with the right toggle switch (lever up "ON").

Select the desired operating frequency by rotating the increment/decrement knobs either clockwise or counterclockwise. A clockwise rotation will increment the previous frequency while a counterclockwise rotation will decrement the previous frequency. The larger inside knob will change the MHz-portion, the smaller outside knob will change the kHz-portion. At one band-edge (000 or 975 kHz) the following 25 kHz change will wrap around to the other band-edge.

### **FSG 71M:**

To select the desired operating frequency rotate the channel selector fully clockwise. To tune the radio to a stored operating frequency rotate the channel selector switch to the desired channel no. (1 to 10). The receiver is always tuned to the frequency appearing in the display.

Set the left toggle switch to "Squelch OFF"-position (lever down) to override the automatic squelch and rotate the "VOL" knob for desired listening level on the noise being produced by the receiver. Set the left toggle switch to "SQ" (lever up) to activate the automatic squelch.

A warm-up period is not required. However, at temperatures of -20°C, the LC display needs approx. 1 sec. until it is fully visible when frequency is changed.

For transmit operation select the desired frequency, depress the push-to-talk button and speak into the microphone. The microphone must be kept close to the lips in order to cancel noise like from the engine etc. Enunciate clearly at a constant loudness.

During transmit operation, the yellow LED "TX"-indicator will light on the front panel, signaling that the push-to-talk button is depressed.

During receive operation rotate the "VOL" knob for desired volume.



### **IMPORTANT!**

- If radio is battery powered frequent transmitting and loud receiver volume reduce available operating time.

### 4.3 Programming the Channel Frequency Memory (FSG 71M only)

The **FSG 71M** transceiver is equipped with 10 memory cells which are able to store one frequency each in the range from 118.000 to 136.975 MHz. The stored frequencies are non-volatile.

1. Rotate channel selector knob fully clockwise.
2. Select the desired frequency by rotating MHz- and kHz knobs.
3. Rotate channel selector knob to desired channel number (1 to 10).
4. Enter the frequency by depressing (approx. 1 sec.) the store button (STO) into the memory. If a frequency is already stored in that certain channel it will be overwritten. The function of the STO button is electrically delayed to reduce memory loss caused by accident touching.

### 4.4 Recall of Stored Frequencies

Rotate channel selector knob to desired channel number. The stored frequency will appear on the display and the transceiver is tuned.



#### Only for Users of FSG 71M Transceivers

If the built-in battery of the electronic memory is defective, the memory content is lost when the unit is switched OFF. For safety reasons the memory battery should be changed every five to six years by authorized personnel (recommended date of change see separate tag on unit).

### 4.5 Battery Check

The **FSG 70-System** transceivers indicate low battery voltage by causing the frequency display to blink if the power supplied drops below 11 volts.

#### When operating from battery:

Depending on battery capacity and the duration of transmit operation, the following operating times may remain after blinking starts until the battery is fully exhausted.

Reference: approx. 20°C, 6.5 Ah battery, feeding only the transceiver. Operating conditions: 10% transmit, 20% receive, 70% stand by

ACTION	CONSEQUENCE
a) Blinks while transmitting	Approx. 5 hrs. operation left
b) Blinks also while receiving	Approx. 45 min. operation left Recommendation: Transmit only when absolutely necessary!
c) Short-time blinking in "stand by" mode (switch at "SQ" position, no reception)	Cease transmitting! Approx. 45 min. of receive-only operation left.
d) Continuous blinking in "Stand by" mode	Turn off unit! Recharge battery as soon as possible!  (Refer to Section 4.7 Emergency Operation)



#### IMPORTANT!

- The transitions for a), b), c), and d) have fluent character, the battery recovers somewhat after load is reduced.

When operating from aircraft's power system

Blinking frequency display:

The aircraft's power system must soon be investigated!

When operating from 28 V aircraft power system

Blinking frequency display:

Check voltage regulator and aircraft's power system.

#### **4.6 Emergency Operation**

In an emergency case, the unit can also be operated with supply voltages down to 9.7 Volts. The audio output and transmitting output are of course reduced.

Batteries must always be recharged immediately after emergency operation because extensive discharging incurs the risk of deterioration and permanent damage - this risk is increased if a discharged battery is also stored in that state.

#### **4.7 Squelch Function (SQ)**

With the left toggle switch in the "SQ" position (normal operation), the automatic squelch circuit of the unit, is active. This disables the audio amplifier when the receiver has no signal or one which is too weak. Signals stronger than the threshold (approx. 1 $\mu$ V) enable the audio amplifier and are therefore reproduced in the headphones/loudspeaker; annoying VHF noise is thereby suppressed. Also, considerable power is saved. If, however, very weak signals are to be received (e.g., a glider landing far from base), then the SQ toggle switch is placed in the down position. This permits noise during pauses, but weak signals of marginal strength are no longer suppressed, and the full reception range is available.

#### **4.8 Intercommunication (IC)**

1. Turn on IC mode with IC switch (refer to Fig. 3-7/3-8).
2. Intercommunication is performed via microphone and headphone.
3. Pressing the push-to-talk button activates the transmitter as usual - turning off the IC mode is not required.
4. After releasing the push-to-talk button intercom operation is re-enabled.

#### **4.9 Audio External**

Via the AF-Ext. input a second or third radio (or NAV-receiver, E-Variometer) can be connected to the transceiver. When wired for this purpose, the volume of the external receivers is/are to be set so the signals can be understood, and distinguished one from another.

The VOL control of the **FSG 70/FSG 71M** affects not the volume of the external units, and vice versa.



**Appendix A Certificate**

Anlage 1 zur Zulassungsurkunde  
Nr. LO-94/85 vom 17.09.1997  
Vorgangs-Nr.: 62808  
Seite 1 (2)

**SYSTEMBESCHREIBUNG**

**Objektbestandteile:** UKW-Sprechfunkgerät FSG 70 (PC, PS) oder FSG 71M (PC, PS)

Optionaler Einbau im Tragegestell  
Spannungsversorgung intern oder extern oder mit eingebautelem Ladegerät

**Objektmerkmale:**

Frequenzbereich : 118,000 – 136,975 MHz  
HF-Ausgangsleistung: 6 W  
Sendart : A 3 E  
Kanalabstand : 25 kHz  
Betriebsart : Wechselsprechen auf einer Frequenz  
Spannungsversorgung: 12 V DC

**BUNDESAMT FÜR POST UND TELEKOMMUNIKATION**



**ZULASSUNGSRURKUNDE**

Zulassungsnummer : LO-94/85

**Objektbezeichnung:** FSG 70, FSG 70PS, FSG 70PC, FSG 71M, FSG 71MPS, FSG 71MPC

**Zulassungsinhaber:** Walter Dittfel GmbH  
Erpfinger Straße 36  
D-86839 Landsberg/Lech

**Zulassungsart :** Allgemeinzulassung

**Befristung :** unbefristet

**Objektart :** Funkanlage in Bodenfunkstellen des beweglichen Flugfunks als Sprechfunkanlage

Das Zulassungsobjekt erfüllt die technischen Vorschriften der Richtlinie FZ 17 TR 2013, Ausgabe Juni 1989.

Die Zulassungsurkunde mit Ausstellungsdatum 22.11.85 wird hiermit ungültig.

Saarbrücken, den 17.09.1997

Im Auftrag  
  
Stefan Bach  
1 Anlage



Bundesamt für Post und Telekommunikation, Talstraße 34-42, D-60119 Saarbrücken, Tel.: (06361) 5 06-0, Fax: (06361) 5 09-18 00